

SSIL[®]

USER MANUAL

BTB8

BLUETOOTH[®] • ALL-TERRAIN SOUND SYSTEM
FEATURING 8" MARINE SPEAKERS AND 1" TWEETERS



 **Bluetooth**[®]





TABLE OF CONTENTS

INFORMATION TO THE USER	2
BEFORE YOU START	4
GETTING TO KNOW YOUR BTB8	5
BEFORE YOU START	6
BLUETOOTH OPERATION	7
STREAMING MUSIC	8
AUX INPUT	9
INSTALLATION	10
TROUBLE SHOOTING	11
WIRE DIAGRAM	12
SPECIFICATIONS	12

SUPPORT

For the latest information about this product please visit www.soundstormlab.com

TECH SUPPORT: 805-322-8794
www.soundstormlab.com/technical-support/

All rights reserved. No part of this publication may be reproduced, distributed, or transmitted in any form or by any means, including photocopying, recording, or other electronic or mechanical methods, without the prior written permission of SOUND STORM LABS.

All other trademarks and trade names are those of their respective owners.

Copyright © 2016 SOUND STORM LABS.

Thank you for purchasing this



BTB8 All-Terrain Sound System

Please read through these instructions carefully so you will know how to operate your model properly.

After you have finished reading the instructions, keep this document in a safe place for future reference.

THIS PACKAGE CONTAINS

1- BTB8 8" All-Terrain Speaker System

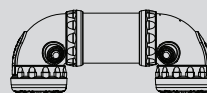

2- Mounting Straps + 2 Nylon Zip Straps



1- Cigarette Extension Adaptor



1- User Manual

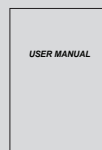

1- Warranty Card



INFORMATION TO THE USER



The Bluetooth® word mark and logos are registered trademarks owned by Bluetooth SIG, Inc. and any use of such marks is under license. Other trademarks and trade names are those of their respective owners.

2



3



INFORMATION TO THE USER

FCC COMPLIANCE STATEMENT

This device complies with part 15 of the FCC Rules. Operation is subject to the following two conditions:

- (1) this device may not cause interference, and
- (2) this device must accept any interference, including interference that may cause undesired operation of this device.

This transmitter must not be co-located or operated in conjunction with any other antenna or transmitter. The Bluetooth antenna cannot be removed (or replaced) by user. This equipment complies with FCC/ IC radiation exposure limits set forth for an uncontrolled environment and meets the FCC radio frequency (RF) Exposure Guidelines and RSS-102 of the IC radio frequency (RF) Exposure rules. This equipment has very low levels of RF energy that it is deemed to comply without maximum permissive exposure evaluation (MPE). But it is desirable that it should be installed and operated keeping the radiator at least 20 cm or more away from person's body (excluding extremities: hands, wrists, feet and ankles). Alteration or modifications carried out without appropriate authorization may invalidate the user's right to operate the equipment.

NOTE: This equipment has been tested and found to comply with the limits for a Class B digital device, pursuant to Part 15 of the FCC Rules. These limits are designed to provide reasonable protection against harmful interference in a residential installation. This equipment generates, uses and can radiate radio frequency energy and, if not installed and used in accordance with the instructions, may cause harmful interference to radio communications. However, there is no guarantee that interference will not occur in a particular installation. If this equipment does cause harmful interference to radio or television reception, which can be determined by turning the equipment off and on, the user is encouraged to try to correct the interference by one or more of the following measures:

- Relocate or reorient the receiving antenna.
- Increase the separation between the equipment and receiver.
- Connect the equipment into an outlet on a circuit different from that to which the receiver is connected.
- Consult the dealer or an experienced radio/TV technician for help.



CAUTION!!
ADJUSTMENT OR ALTERATIONS OF THIS DEVICE MAY RESULT
IN HAZARDOUS RADIATION EXPOSURE.

BEFORE YOU START

IMPORTANT SAFETY PRECAUTIONS

- Do not operate mobile equipment while driving a motorized vehicle – safe driving and safety consideration of others should always be your highest priority.
- In the event you should notice smoke, strange noises or odor from this product, or any other abnormal signs, immediately turn off the power and consult your dealer or the nearest authorized **SOUND STORM LABS** Service Center. Using this product in this condition may result in permanent damage to the system.
- Set your volume control at a low setting, then slowly increase the sound until you can hear it comfortably without distortion, or ear discomfort.
- **BE SURE TO OBSERVE THE FOLLOWING GUIDELINES:**
 - Do not turn up the volume so high that you can't hear what's around you.
 - Use caution or temporarily discontinue use in potentially hazardous situations.

INSTALLATION PRECAUTIONS

WARNING - Always consult a professional installer

- Do not attempt to install or service this product by yourself. Installation or servicing of this product by persons without professional training and experience in electronic equipment and motorized vehicle accessories may be dangerous and could expose you to the risk of electric shock, injury or other hazards
- Refer any repairs to a qualified **SOUND STORM LABS** Service Center
- The BTB8 can be powered from a vehicles cigarette lighter / auxiliary power port, or hard wired directly to the battery through an optional relay / accessory switch
- When wiring directly to the vehicles battery, be sure to disconnect the batteries negative terminal wire before starting any wiring procedures, it is suggested that an optional fuse and fuse holder (not included) with minimum rating of 15 Amps be in line with the positive battery terminal
- The ground cable length should not exceed 18-inches (See wiring diagram)
- The BTB8 has a weather resistant design, it should not be submerged in or under water under any circumstances
- Use only the installation parts provided with the BTB8
- Wash with a mild soap or detergent and lukewarm water using a clean sponge or a soft cloth. Rinse well with clean water.

“Don'ts” - Very Important

- DON'T clean in hot sun or on very hot days.
- DON'T use abrasive or highly alkaline cleaners on the main body
- DON'T scrape the main body with razor blades, or other sharp instruments
- DON'T ever use, gasoline, acetone or carbon tetrachloride

CAUTION!!

Using other mounting methods may void this warranty

4



SOUND STORM
LABORATORIES

GETTING TO KNOW YOUR BTB8

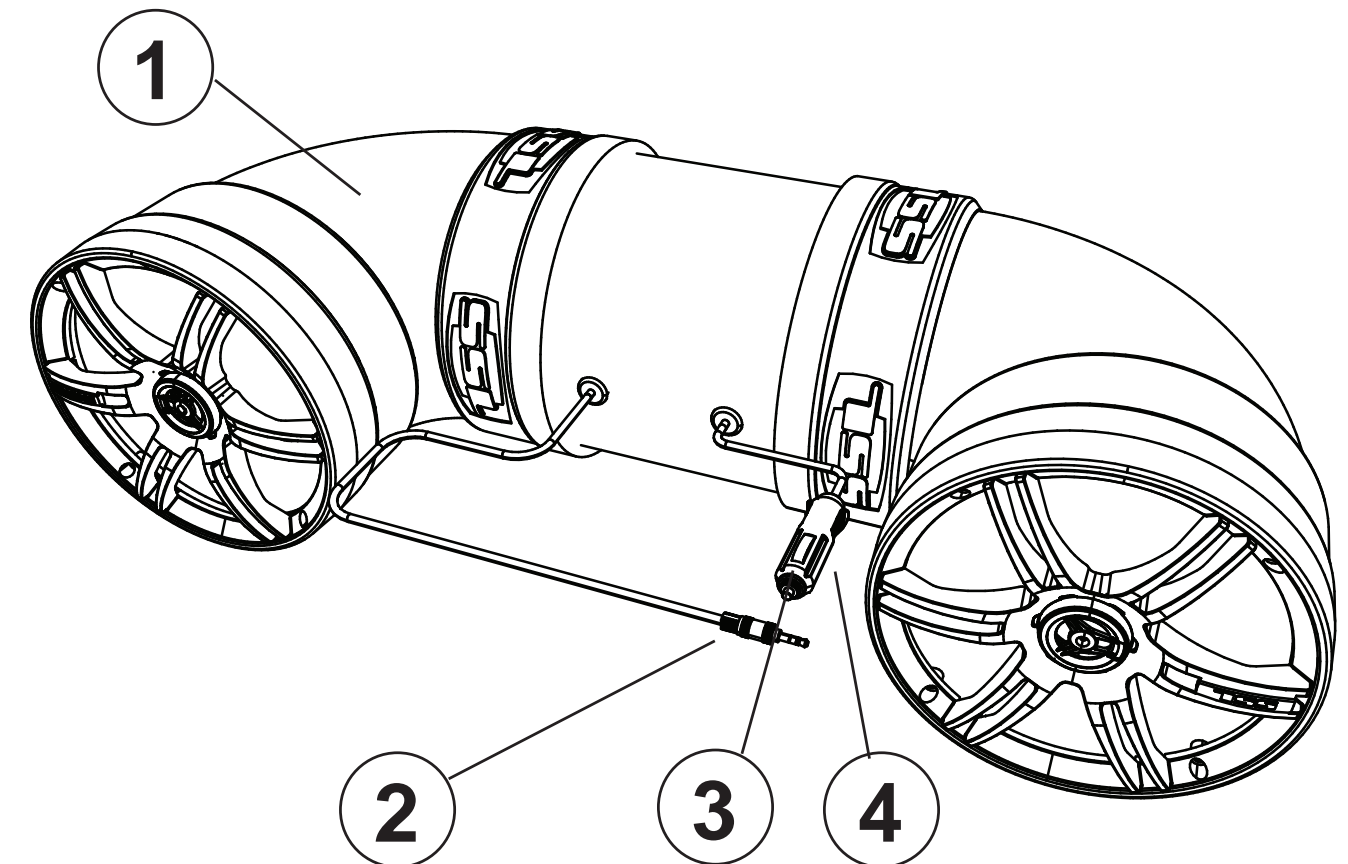

1

BTB8 BOOMTUBE

2

3.5mm AUX-INPUT

3

CIGARETTE POWER CABLE ADAPTOR

4

LED POWER INDICATOR

5



SOUND STORM
LABORATORIES

BLUETOOTH OPERATION

ENGLISH

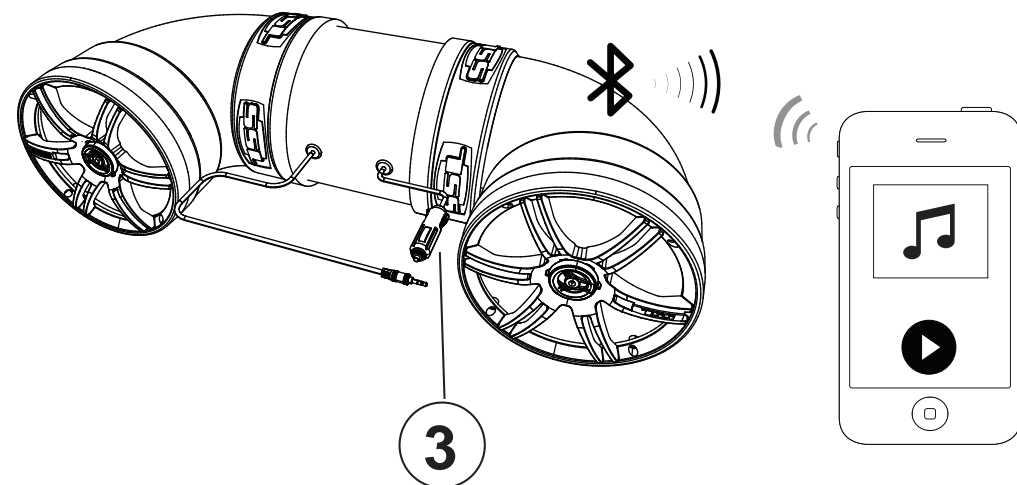

PAIRING & DISCOVERING A NEW BLUETOOTH CONNECTION

1) Power on the **BTB8** by plugging in the male cigarette lighter adaptor into **3** a female cigarette lighter receptacle.

2) The **BTB8** will automatically go in to pairing mode:

ANDROID users:

- Go into the **Settings Menu** of your device
- Enter the **Bluetooth Menu**
- TURN ON Bluetooth** and press **SCAN**
- "SSL BTB8"** will now be displayed under **AVAILABLE DEVICES**
- If prompted, enter passcode: **"0000"**

iOS users:

- Go into the **Settings Menu** of your **iOS** device
- Enter the **Bluetooth Menu**
- TURN ON Bluetooth**
- "SSL BTB8"** will now be displayed
- If prompted, enter passcode: **"0000"**

NOTE: You have 2 minutes before you must restart this procedure over again.

3) If **SSL BTB8** is not seen, repeat the above steps to refresh the **"Device List"**

4) When the connection is successful, you are now ready to stream music from your favorite media player to the **BTB8**

6



BLUETOOTH OPERATION

ENGLISH

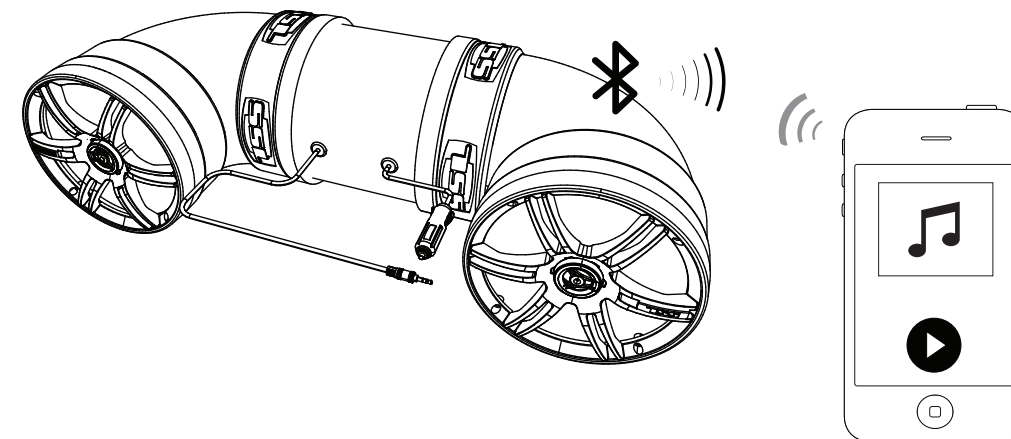

RECONNECTION

1) Power on the **BTB8** and your last paired **Bluetooth device**.

2) The unit will now automatically reconnect

3) If your device was previously paired with the **BTB8**, but it wasn't the last paired **device**:

- Ensure no other **devices** are currently paired
- Enter the **Bluetooth Menu** on your device being paired
- "SSL BTB8"** will display under **AVAILABLE DEVICES**
- Choose the **"SSL BTB8"** to reconnect

4) If the device is out of range from the **BTB8**, it will disconnect automatically:

- The **BTB8** will automatically reconnect to the device once back in range

NOTE: Some media devices will need to be manually reconnected from the device Bluetooth settings menu



Tips:

To avoid battery exhaustion, be sure to occasionally run the vehicles engine while using this product. Using this product without running the engine can drain the battery.

7



STREAMING MUSIC

ENGLISH

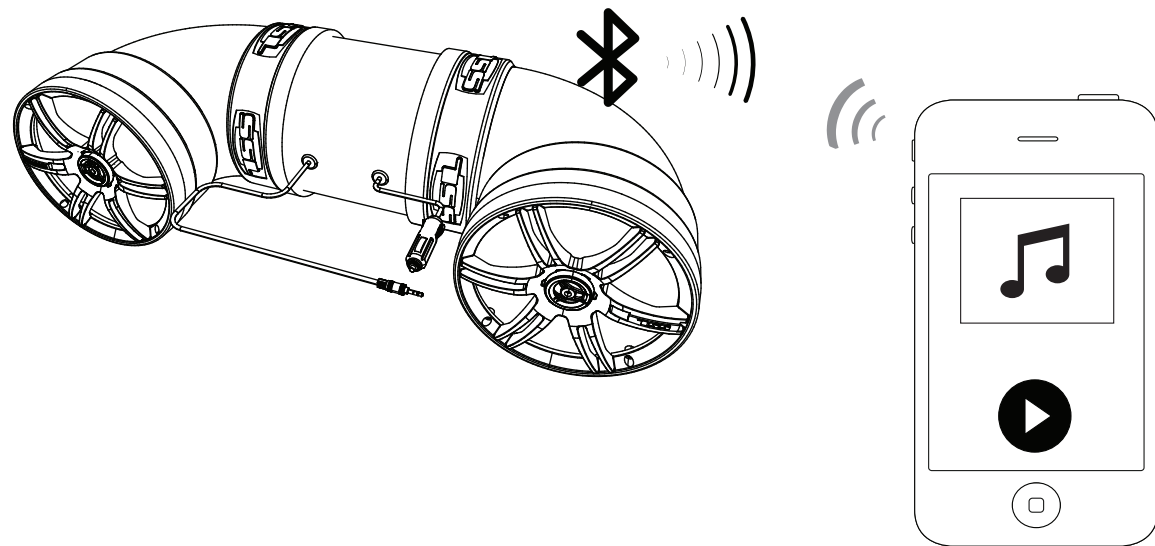

BLUETOOTH OPERATION

- 1) Press the **PLAY/PAUSE** from your devices touch screen

VOLUME CONTROL

- 2) To **raise or lower** the **volume** use your device volume controls

 **Tips:** For maximum audio performance, ensure your device Bluetooth volume is set to a minimum 75% level before stowing

8



AUX INPUT

ENGLISH

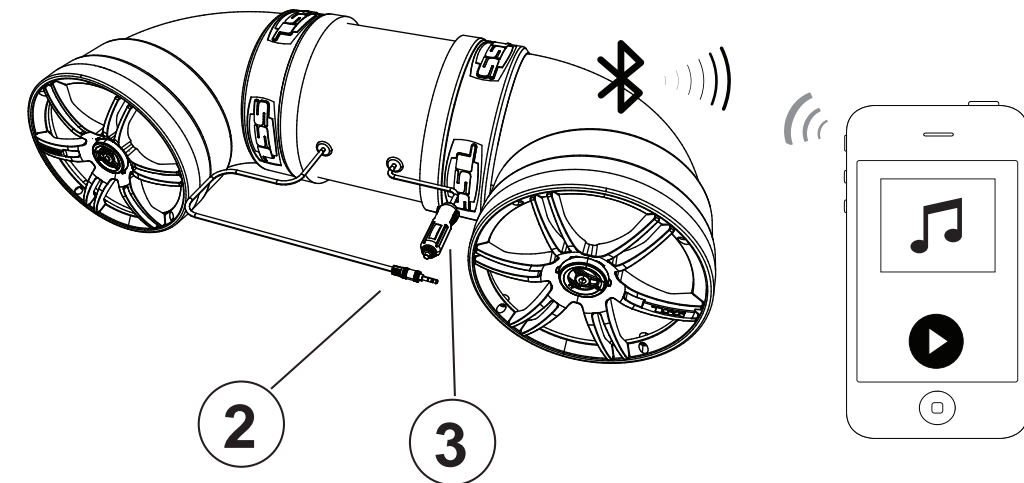

BTB8 can play audio from any device that has a 3.5mm headphone audio jack.

AUX-IN OPERATION

- 1) Power on the **BTB8** by plugging in the male cigarette lighter adaptor into **3** a female cigarette lighter receptacle.
- 2) Disconnect any paired **Bluetooth** device by turning off **Bluetooth** in your devices **Settings Menu**
- 3) Connect the integrated 3.5mm **AUX-IN** cable **2** to your devices headphone jack
- 4) Route the wire back to **BTB8**, and secure your device

VOLUME CONTROL

- 5) To **raise or lower** the **volume** use your device volume controls

 **Tips:** For maximum audio performance, ensure your device headphone volume is set to a minimum 75% level before stowing

9



INSTALLATION

ENGLISH

1) Use the supplied adjustable straps to secure to rails or roll bars

2) Always recheck straps before every ride

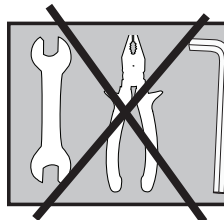
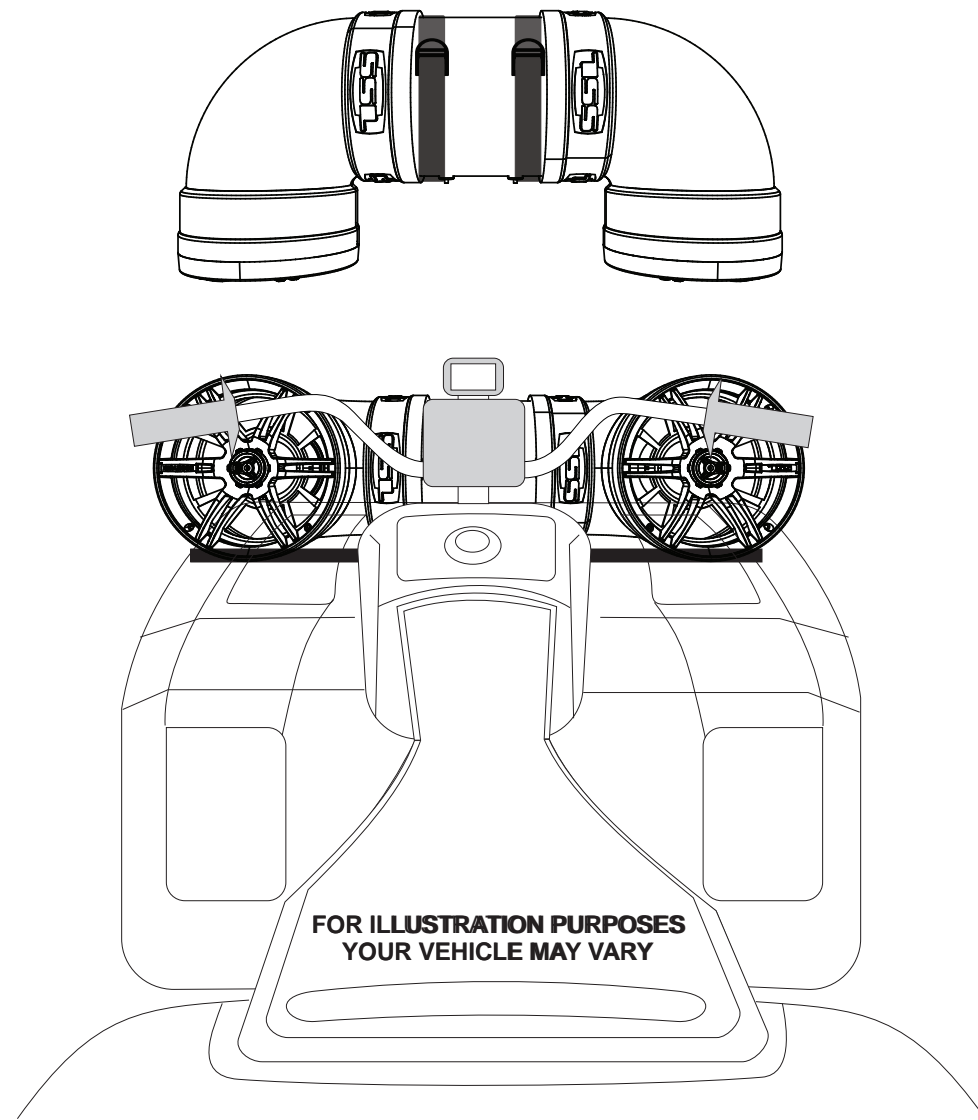

NO SPECIAL TOOLS REQUIRED

10



TROUBLE SHOOTING

ENGLISH

TROUBLE	CAUSE	SOLUTION
Unit will not turn on	The fuse is blown	Check / replace the fuse
	Main acc switch not engaged	Turn switch to on position
No sound is heard	Device volume is low / muted	Turn the volume level up
	Device is paused or muted	Check your devices playing / volume status
Cannot pair Bluetooth	The Bluetooth function of the device is not enabled	Refer to the user manual of the device for how to enable the Bluetooth function
The audio quality is poor after connection with a Bluetooth enabled device	The Bluetooth reception is poor	Move the device closer to the audio system or remove any obstacle between the device
Unit has become unresponsive	Power glitch or interference	Disconnect power for 10 seconds to reset

SUPPORT

For the latest information about this product please visit www.soundstormlab.com

TECH SUPPORT: 805-322-8794
www.soundstormlab.com/technical-support/

DIMENSIONS

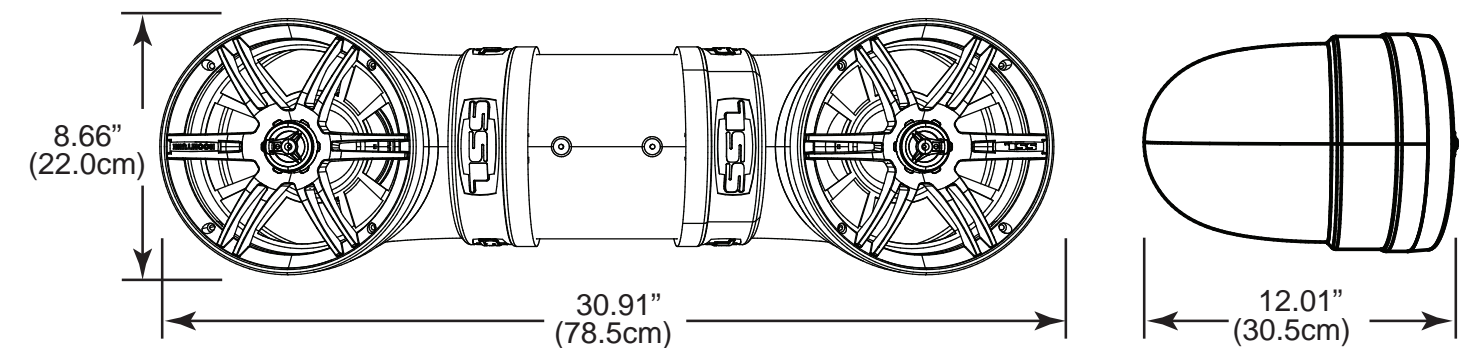

11

WIRE DIAGRAM

ENGLISH

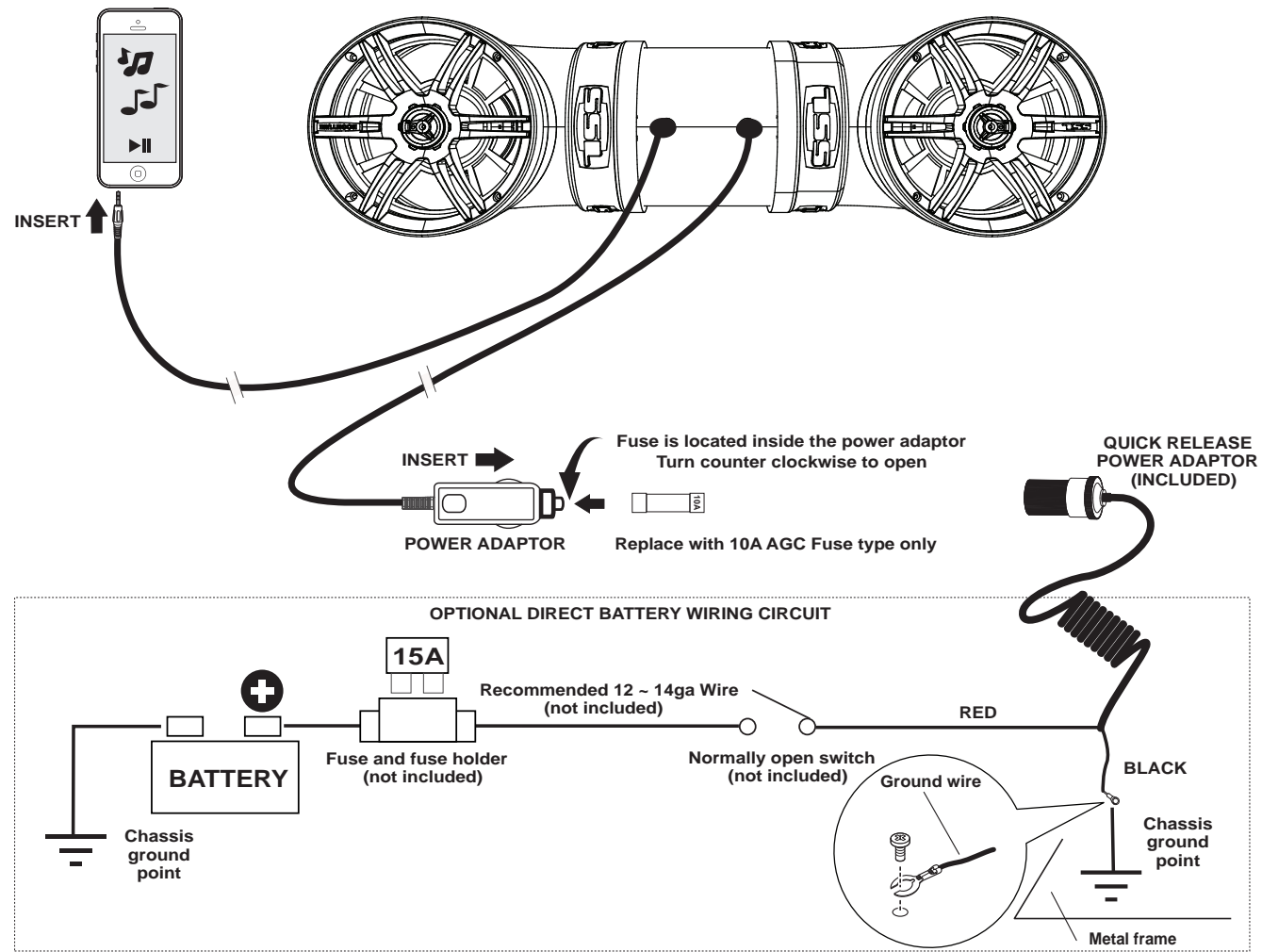

SPECIFICATIONS

BLUETOOTH

- Version: 3.0 w/ EDR
- A2DP
- Range: 33ft (10m)

AMPLIFIER

- Class D
- Maximum Output Power: 700 Watts
- Input impedance: 10kΩ
- Frequency Response: 45Hz-22kHz

SPEAKERS

- Dimensions: 8" / 203.3mm
- Cone Type: PP CARBON + RUBBER SURROUND
- Tweeter Size: 1" PEI SOFT DOME

GENERAL

- Operational Power: 12VDC (10-16V allowable)
- MAX Current Draw: 10A
- Replacement Fuse: 10A AGC TYPE
- Color: Black
- Net Weight: 12.7lbs / 5.75kg
- Dimensions cm WxHxD: 78.5 x 27.0 x 30.5
- Dimensions Inches WxHxD: 30.91 x 8.66x 12.01

SPECIFICATIONS SUBJECT TO CHANGE WITHOUT NOTICE

12





SOUND STORM LABORATORIES

3451 Lunar Court, Oxnard CA 93030

TECHNICAL ASSISTANCE

www.soundstormlab.com/technical-support/
805-322-8794

BTB8

BLUETOOTH® • ALL-TERRAIN SOUND SYSTEM



EN 216